

**DIGITRAK® MFD®**

**Multi-Function Display**

**&**

**DIGITRAK® FSD™**

**F Series Display**

# Operator's Manual



**DCI Headquarters**  
19625 62nd Ave. S., Suite B-103  
Kent, Washington 98032 USA  
Tel 425 251 0559 / 800 288 3610 Fax 253 395 2800  
E-mail [DCI@digital-control.com](mailto:DCI@digital-control.com) [www.digitrak.com](http://www.digitrak.com)

**DCI Europe**

Kurmainzer Strasse 56  
D-97836 Bischbrunn  
Germany  
Tel +49(0) 9394 990 990  
Fax +49(0) 9394 990 999  
[DCI.Europe@digital-control.com](mailto:DCI.Europe@digital-control.com)

**DCI India**

SCO # 259, Sector 44-C  
Chandigarh (UT) 160 047  
Punjab, India  
Tel +91(0) 172 464 0444  
Fax +91(0) 172 464 0999  
[DCI.India@digital-control.com](mailto:DCI.India@digital-control.com)

**DCI China**

No. 41, Lane 500, Xingle Road  
Huacao Town, Minhang District  
Shanghai P.R.C. 201107  
Tel +86(0) 21 6432 5186  
Fax +86(0) 21 6432 5187  
[DCI.China@digital-control.com](mailto:DCI.China@digital-control.com)

**DCI Australia**

2/9 Frinton Street  
Southport, Queensland 4215  
Australia  
Tel +61(0) 7 5531 4283  
Fax +61(0) 7 5531 2617  
[DCI.Australia@digital-control.com](mailto:DCI.Australia@digital-control.com)

**DCI Russia**

420059 Pavlyukhina Street  
104, Kazan  
Russia  
Tel +7 843 277 52 22  
Fax +7 843 277 52 07  
[DCI.Russia@digital-control.com](mailto:DCI.Russia@digital-control.com)

3-3200-00-C

© 2009 by Digital Control Incorporated. All rights reserved. October 2009 edition.

## Trademarks

The DCI logo, DigiTrak<sup>®</sup>, DataLog<sup>®</sup>, Eclipse<sup>®</sup>, F2<sup>®</sup>, MFD<sup>®</sup>, SST<sup>®</sup>, *target-in-the-box*<sup>®</sup>, *Target Steering*<sup>®</sup>, and TensiTrak<sup>®</sup> are U.S. registered trademarks and F Series<sup>™</sup>, FSD<sup>™</sup>, *FasTrak*<sup>™</sup>, and SE<sup>™</sup> are trademarks of Digital Control Incorporated.

## Limited Warranty

All products manufactured and sold by Digital Control Incorporated (DCI) are subject to the terms of a Limited Warranty. A copy of the Limited Warranty is included this manual; it can also be obtained by contacting DCI Customer Service, 800-288-3610 or 425-251-0559, or by connecting to DCI's website, [www.digitrak.com](http://www.digitrak.com).

## Important Notice

All statements, technical information, and recommendations related to the products of DCI are based on information believed to be reliable, but the accuracy or completeness thereof is not warranted. Before utilizing any DCI product, the user should determine the suitability of the product for its intended use. All statements herein refer to DCI products as delivered by DCI and do not apply to any user customizations not authorized by DCI nor to any third-party products. Nothing herein shall constitute any warranty by DCI nor will anything herein be deemed to modify the terms of DCI's existing Limited Warranty applicable to all DCI products.

## FCC Warning Statement

This equipment has been tested and found to comply with the limits for a Class B digital device, pursuant to Part 15 of the Rules of the Federal Communications Commission (FCC). These limits are designed to provide reasonable protection against harmful interference in a horizontal directional drilling installation. This equipment generates, uses, and can radiate radio frequency energy and, if not installed and used in accordance with the instructions, may cause harmful interference to radio communications or inaccurate readings on your DCI locating equipment. However, there is no guarantee that interference will not occur in a particular installation. If this equipment does cause harmful interference to radio or television reception, which can be determined by turning the equipment off and on, the user is encouraged to try to correct the interference by one or more of the following measures:

- Reorient or relocate the DCI receiver.
- Increase the separation between the problematic equipment and the DCI receiver.
- Connect the equipment into an outlet on a different circuit.
- Consult the dealer for help.

Changes or modifications to the DCI equipment not expressly approved and carried out by DCI will void the user's Limited Warranty and the FCC's authorization to operate the equipment.

## FCC Compliance Statement

This device complies with Part 15 of the Rules of the FCC. Operation is subject to the following two conditions: (1) this device may not cause harmful interference, and (2) this device must accept any interference received, including interference that may cause undesired operation. DCI is responsible for FCC compliance in the United States: Digital Control Incorporated, 19625 62<sup>nd</sup> Ave. S., Suite B-103, Kent, WA 98032; phone 425-251-0559 or 800-288-3610.

**WARNING:** Changes or modifications to any DCI equipment not expressly approved and carried out by DCI could void the user's authorization to operate the equipment.

## *Table of Contents*

SAFETY PRECAUTIONS AND WARNINGS.....	4
DEAR CUSTOMER:.....	6
INTRODUCTION.....	7
BASIC INSTRUCTIONS .....	9
Power Options .....	9
Connecting the DC Power Cable.....	10
Installing MFD Battery Pack .....	10
Installing FSD Battery Pack or Brace Insert .....	11
Keypad .....	11
Power On/Off.....	11
Adjusting Screen Contrast.....	11
Adjusting Viewing Angle.....	12
Attaching and Removing Visor .....	12
Speaker and Audible Tones .....	13
Main Menu.....	13
Contrast Adjustment .....	14
Settings Menu.....	15
REMOTE MODES.....	17
F2 and Eclipse Modes .....	17
Main Display Screens .....	17
Depth Display Screens .....	18
Target Steering Display Screen.....	19
TensiTrak Mode (Eclipse Only) .....	20
SE Series Mode.....	21
Main Display Screen.....	21
Depth Display Screens .....	21
Remote Steering Display Screen.....	23
Mark Series Mode .....	24
Main Display Screens (Mark II, III, IV, and V).....	24
Depth Display Screens (Mark IV/V) .....	25
LIMITED WARRANTY	

# Safety Precautions and Warnings

**Important Note:** All operators must read and understand the following Safety Precautions and Warnings and must review this *Operator's Manual* as well as the operator's manual for your DCI locating system.

⚠ Serious injury and death can result if underground drilling equipment makes contact with an underground utility such as a high-voltage electrical cable or a natural gas line.

▽ Substantial property damage and liability can result if underground drilling equipment makes contact with an underground utility such as a telephone, fiber-optic, water, or sewer line.

🕒 Work slowdowns and cost overruns can occur if drilling operators do not use the drilling or locating equipment correctly to obtain proper performance.

- Directional drilling operators **MUST** at all times:
  - Understand the safe and proper operation of drilling and locating equipment, including the use of ground mats and proper grounding procedures.
  - Ensure that all underground utilities have been located, exposed, and marked accurately prior to drilling.
  - Wear protective safety clothing such as dielectric boots, gloves, hard-hats, high-visibility vests, and safety glasses.
  - Locate and track the transmitter in the drill head accurately and correctly during drilling.
  - Comply with state and local governmental regulations (e.g., OSHA).
  - Follow all other safety procedures.
- DCI horizontal directional drilling locating systems cannot be used to locate utilities.
- Continued exposure to heat, due to frictional heating of the transmitter in the drill head from drilling in sand, gravel, or rock without sufficient fluid flow around the transmitter, can cause inaccurate information to be displayed and may permanently damage the transmitter. For more information see the *Transmitter* section of this manual.

⚠ The DigiTrak MFD and FSD are not explosion-proof and should never be used near flammable or explosive substances.

## ***Safety Precautions and Warnings (Continued)***

- Remove the batteries during shipping and prolonged storage.
  
- Prior to the start of each drilling run, test your DCI locating system to confirm that it is operating properly and check that it is providing accurate drill head location and heading information and accurate transmitter depth, pitch, and roll information.
  
- During drilling, the depth will not be accurate unless:
  - The receiver has been properly calibrated and the calibration has been checked for accuracy so that the receiver shows the correct depth.
  - The transmitter has been located correctly and accurately and the receiver is directly above the transmitter in the drill head underground or at the front locate point.
  - The receiver is kept level and the height-above-ground or ultrasonic distance has been set correctly.
  
- Interference can cause inaccuracies in the measurement of depth and loss of the transmitter's pitch, roll, or heading. You should always perform an electrical interference check prior to drilling.
  - Sources of interference include but are not limited to traffic signal loops, invisible dog fences, cable TV, power lines, fiber-trace lines, metal structures, cathodic protection, telephone lines, cell phones, transmission towers, conductive earth, salt water, rebar, radio frequencies, and other unknown sources of interference.
  - Interference with the operation of the remote display may also occur from other sources operating nearby on the same frequency, such as car rental agencies using their remote check-in modules, other directional drilling locating equipment, etc.
  
- Carefully review this manual and be sure you always operate your DCI locating system properly to obtain accurate depth, pitch, roll, and locate points. If you have any questions about the operation of the system, please call DCI's Customer Service Department at any of the phone numbers provided on the cover, and we will do our best to assist you.

## ***Dear Customer:***

Thank you for choosing a DCI locating system. We are proud of the equipment that we have been designing and building in Washington State since 1990. We believe in providing a unique, high-quality product *and* standing behind it with superior customer service and training.

Please take the time to read this entire manual—especially the section on safety. Also, please fill in the product registration card provided with this equipment, and mail it to DCI headquarters or fax it to us at 253-395-2800; you can also complete and submit the form online at our website. We will put you on the Digital Control mailing list and send you product upgrade information and our *FasTrak™* newsletter.

Feel free to contact us at any of our global offices listed on the front cover if you have any problems or questions. Our Customer Service Department is available 24 hours a day, 7 days a week to provide assistance.

As the horizontal directional drilling industry grows, we're keeping our eye on the future to develop equipment that will make your job faster and easier. Stay current by visiting our web site on the internet at **[www.digitrak.com](http://www.digitrak.com)** or by giving us a call.

We welcome questions, comments, and ideas.

Digital Control Incorporated  
Kent, Washington  
2009

## *Introduction*



### ***DigiTrak MFD and FSD Remotes Are Compatible with DigiTrak Mark III, Mark IV, Mark V, Eclipse, F2, and SE Receivers***

The DigiTrak Multi-Function Display (MFD) and F Series Display (FSD) are remote displays that can accept telemetry signals from your DigiTrak Mark Series, Eclipse, F2, or SE receiver. The MFD or FSD remote must be set up correctly to receive signals from your receiver. It can also receive signals from the Eclipse cable and SST transmitters. Contact DCI for more information on the Eclipse cable and SST transmitters, which require additional equipment and instructions.

This manual explains how to use the DigiTrak MFD and FSD remotes. It provides information on powering the MFD or FSD remote, navigating the menus, setting up the device to receive signals from your receiver, and understanding the display screens. Specific information is presented for the different modes: DigiTrak F2, Eclipse, TensiTrak, SE, and Mark Series.

An external 13 in. (33 cm) telemetry antenna is supplied with your DCI equipment. It mounts onto the remote display to enhance signal reception up to 1800 ft (550 m) with line of sight to the receiver. For bore lengths greater than this or when line of sight is compromised, DCI offers additional telemetry antennas for purchase.

An internal speaker emits audible tones to warn of transmitter temperature increases and is tested every time the unit is powered on.

To meet global requirements and for proper communication with the receiver, one of the frequency designations shown on the remote display's serial number label must match that shown on the receiver's label.

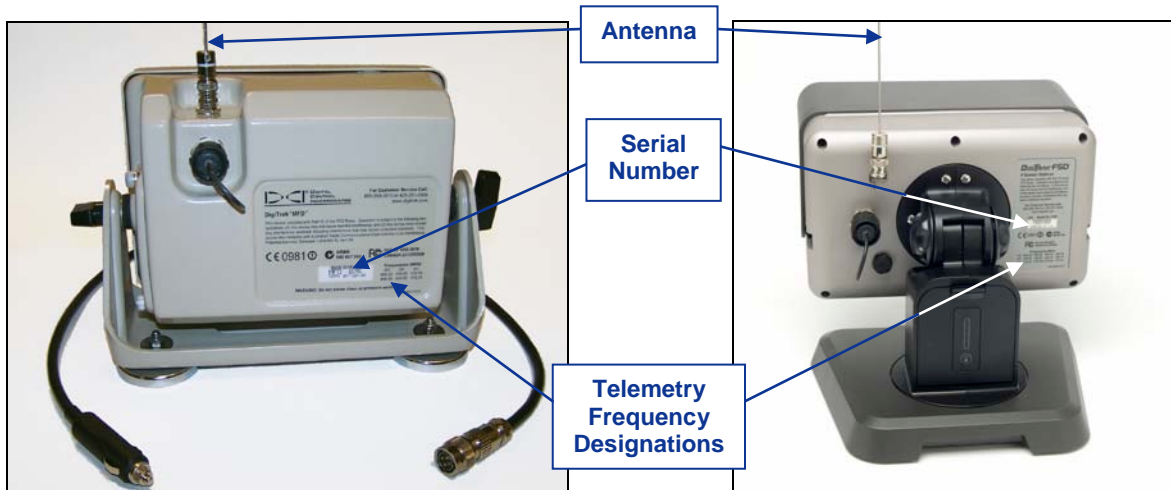

***Serial Number Label  
on Back of MFD Remote***

***Serial Number Label  
on Back of FSD Remote***

This manual does not give instructions on how to operate the locating systems. You must read the operator's manual for your locating system before trying to use it with the MFD or FSD remote. Call DCI if you have any questions.

## Basic Instructions

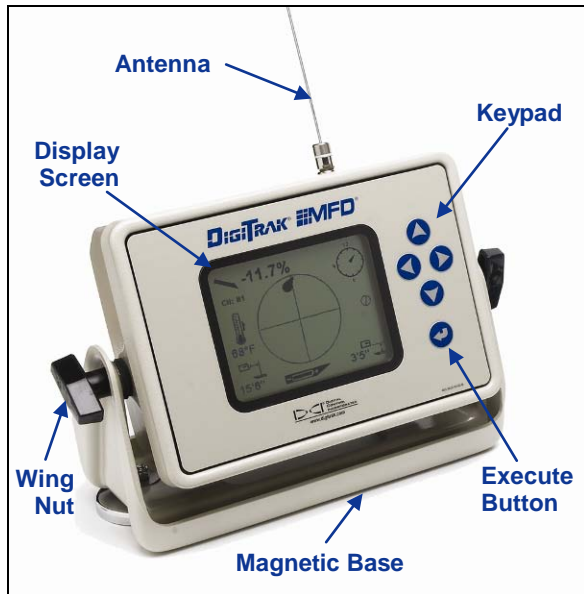

**MFD Remote**



**FSD Remote**

## Power Options

The MFD and FSD remotes can be powered with a DCI battery pack or from a 10-32 V DC power source using the DC power cable. If both a battery pack and the DC power cable are installed, the remote will draw power from the battery pack until the battery voltage is below the DC source voltage.



**DC Power Cable**



**DCI Battery Packs**

The MFD remote requires one of the DCI battery packs shown to the left. The FSD remote requires the DCI lithium-ion battery pack shown to the right.

The battery status of the DCI lithium-ion battery pack can be checked by pressing the battery status button on the battery pack.

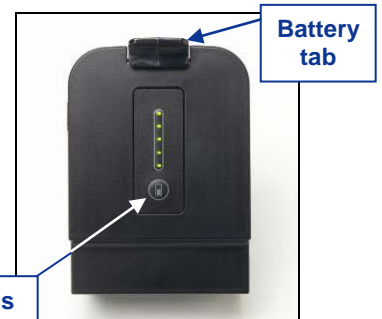

**DCI Lithium-Ion Battery Pack**

## Connecting the DC Power Cable

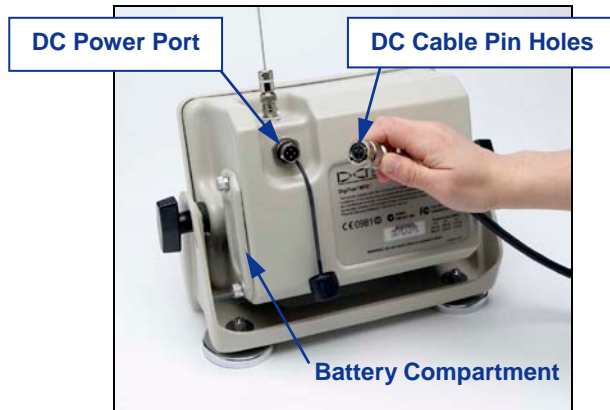

**Connecting DC Power Cable to MFD Remote**

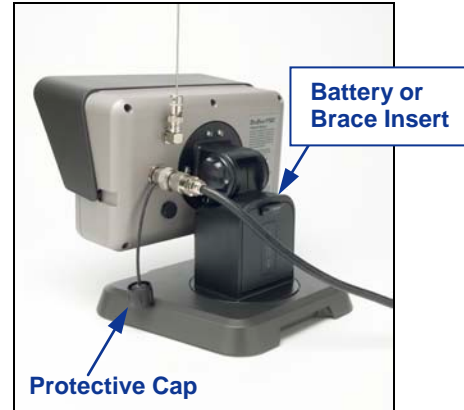

**DC Power Cable Installed in FSD Remote**

To connect the DC power cable:

1. Remove the protective cap on the power port by rotating it counterclockwise.
2. The DC cable and power port are keyed to ensure proper alignment. Line up the keyed slots and DC cable's four pin holes with the four pins in the DC power port on the remote.
3. Push in and rotate the cable connector clockwise until the cable is secure.
4. Install the other end of the DC cable into the DC power source.

**Note:** If the FSD remote's power is supplied via the DC cable, the brace insert must be installed for structural integrity. The brace insert looks like and is installed like a DCI lithium-ion battery.

## Installing MFD Battery Pack

To install the DCI battery pack in the MFD remote:

1. Remove the battery compartment cover by rotating the thumb screws counterclockwise.
2. Insert the battery pack into the battery compartment, terminal end in first, as shown.
3. Reattach the battery compartment cover by holding it in place while pushing in and rotating the thumb screws clockwise.



**Inserting MFD Battery**

## Installing FSD Battery Pack or Brace Insert

To install the DCI lithium-ion battery pack or brace insert in the FSD remote:

1. Hold the battery/brace insert with the tab up and facing away from the FSD remote.
2. Insert the battery/brace insert into the FSD remote's battery compartment, and push on the battery/brace insert until the tab latches in place.



*Installing FSD Battery*

## Keypad

The keypad to the right of the display window is used to operate the MFD and FSD remotes.

**Execute Button** – The execute button (curved arrow) turns on the remote and selects a highlighted menu option. It is also used for adjusting the screen contrast as discussed below.



**Direction Buttons** – The direction buttons are used to navigate menu options. The down button is also used to access the main menu from the remote mode screen. (See “Main Menu” later in this section.)



## Power On/Off

Once you have provided power to the remote, either using the battery pack or a DC power source, then you can operate the unit. The power on and off functions are as follows.

**Power On** – Press the execute button for a half-second or more to turn on the unit. You will hear a tone and the main display screen for the last mode used will appear. If you do not hear a tone, there may be a problem with the internal speaker; call DCI for customer support.

**Power Off** –To turn off the remote, you must access the main menu by pressing the down button and selecting the power off option. See the instructions for using the main menu later in this section.

## Adjusting Screen Contrast

There are two ways to adjust the screen contrast. The easiest method is to hold in the execute button while pushing the right arrow (to lighten the display) or the left arrow (to darken the display). Each time the left or right arrow button is pressed, the contrast will change incrementally. The other way is by using the contrast adjustment option in the main menu. (See “Main Menu” later in this section.)

## Adjusting Viewing Angle

The MFD remote allows you to adjust the viewing angle through a range of 180° up/down. The FSD remote allows you to adjust the viewing angle through a range of 180° left/right, 90° up/down, and 270° about the display's center.

**Up/Down** – To adjust the MFD remote's viewing angle, loosen the large black wing nuts on the sides of the remote, position the display as desired, and tighten the wing nuts. Do not overtighten to avoid damaging the housing.

To adjust the FSD remote's up/down viewing angle, loosen and squeeze the two knobs on the back of the FSD unit, adjust the screen as desired, and tighten the knobs. If the knobs are loose, the display will hold its vertical position only until the knobs are squeezed together or the display is vibrated. Thus, DCI recommends tightening the knobs before drilling.



*Loosen Display Knobs*

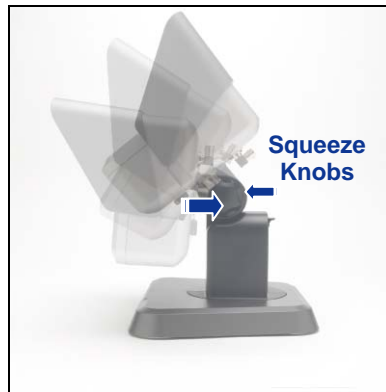

*Adjust Viewing Angle*



*Tighten Display Knobs*

**Left/Right** – When the FSD remote's magnetic base is secure, adjust the left/right viewing angle by rotating the display about the base.

**Center** – With the magnetic base secure, take hold of the display and rotate it to the desired orientation.

## Attaching and Removing Visor

The removable visor on the FSD remote shields the screen from environmental conditions such as rain and sun. The visor is held in place by a ridge on the top of the display and channels on the sides of the display. The antenna must be removed when installing or removing the visor.

To install the visor, slide the visor's pegs along the peg channels on the sides of the display until the visor locks over the ridge.

To remove the visor, push the visor back over the ridge and along the channels.

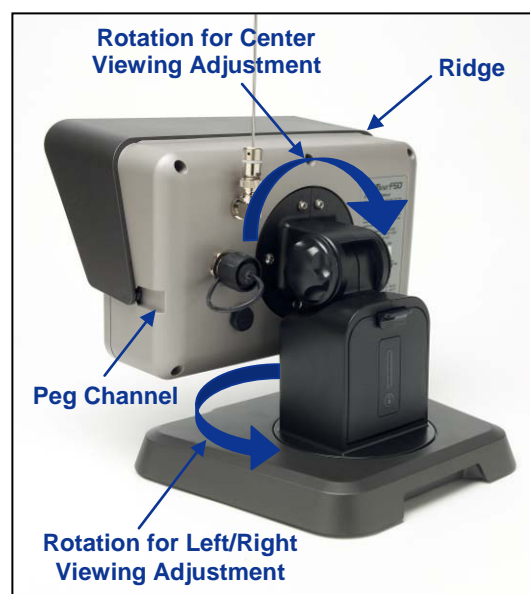

## Speaker and Audible Tones

The audible tones emitted by the MFD and FSD remotes to indicate an increase in the transmitter temperature are summarized in the table below.

### Transmitter Temperature Warning Tones

Temperature	Warning Tones
Below 61°F (16°C)	No tones for temperature increases.
61°F-97°F (16°C-36°C)	Double-beep sequence (beep-beep) for every 4°C increase in temperature.
104°F-111°F (40°C-44°C)	Two double-beep sequences (beep-beep, beep-beep) for every 4°C increase in temperature. <b>NOTE:</b> Action is required to cool the transmitter.
118°F-133°F (48°C-56°C)	Three double-beep sequences (beep-beep, beep-beep, beep-beep) for every 4°C increase in temperature. <b>NOTE:</b> Cooling is critical to avoid irreversible damage.
Above 140°F (60°C)	Three double-beep sequences every five seconds. <b>NOTE:</b> Dangerous drilling conditions; irreversible damage may have already been done.
Above 183°F (84°C)	Transmitter shuts down.
220°F (104°C)	Transmitter overheat indicator (temp dot) turns black.

Normal drilling temperatures range from 64°F (16°C) to 104°F (40°C). Once the temperature reaches 104°F (40°C) the thermometer icon will appear as .

## Main Menu



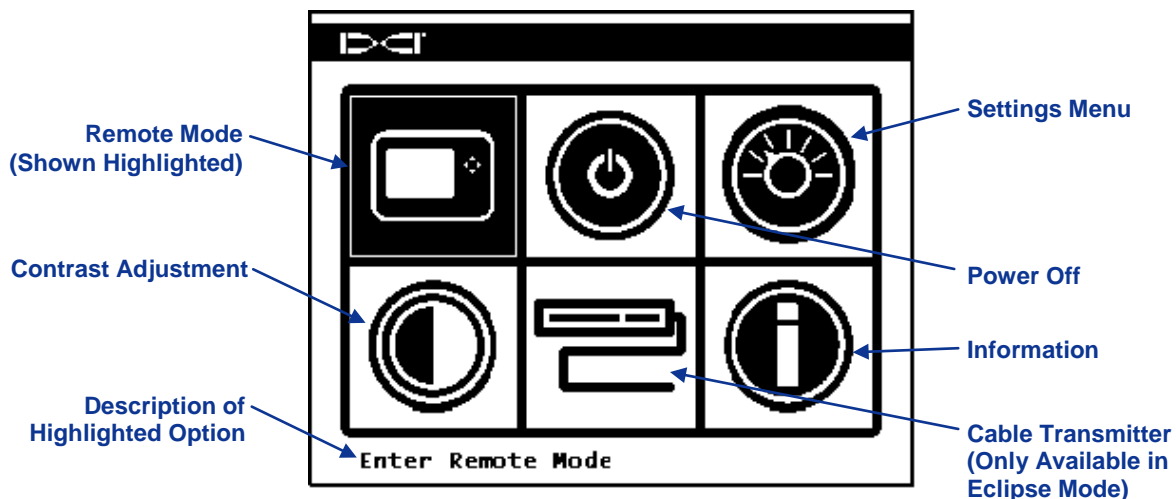



The main menu is accessed by pushing the down direction button.



**Main Menu Screen**

Use the direction buttons to highlight an option, and then press the execute button to select it. The table below lists the main menu options and the result for selecting each item.

## Main Menu Options

	<p><b>Remote Mode</b> – Puts the MFD or FSD unit into remote radio mode. The unit will then display information including transmitter pitch, roll, temperature, battery status, depth, predicted depth, and <i>Target Steering</i> information sent from the receiver. The correct remote mode must be selected to communicate with your receiver. See the “Settings Menu” to change the remote mode.</p>
	<p><b>Power Off</b> – Turns the unit off with no audible signal.</p>
	<p><b>Settings Menu</b> – Opens the settings menu to select receiver model, telemetry channels, or pitch and depth units. See “Settings Menu” below.</p>
	<p><b>Cable Transmitter</b> – Puts the MFD or FSD remote in cable mode for reading cable transmitters. Only accessible from Eclipse mode; requires a cable box. Contact DCI for more information about the cable box.</p>
	<p><b>Contrast Adjustment</b> – Allows you to adjust screen contrast. See below for instructions.</p>
	<p><b>Information</b> – Displays system information such as the software version, the serial number, and the current display settings.</p>

## Contrast Adjustment

When the contrast adjustment option is selected from the main menu, the following screen appears.

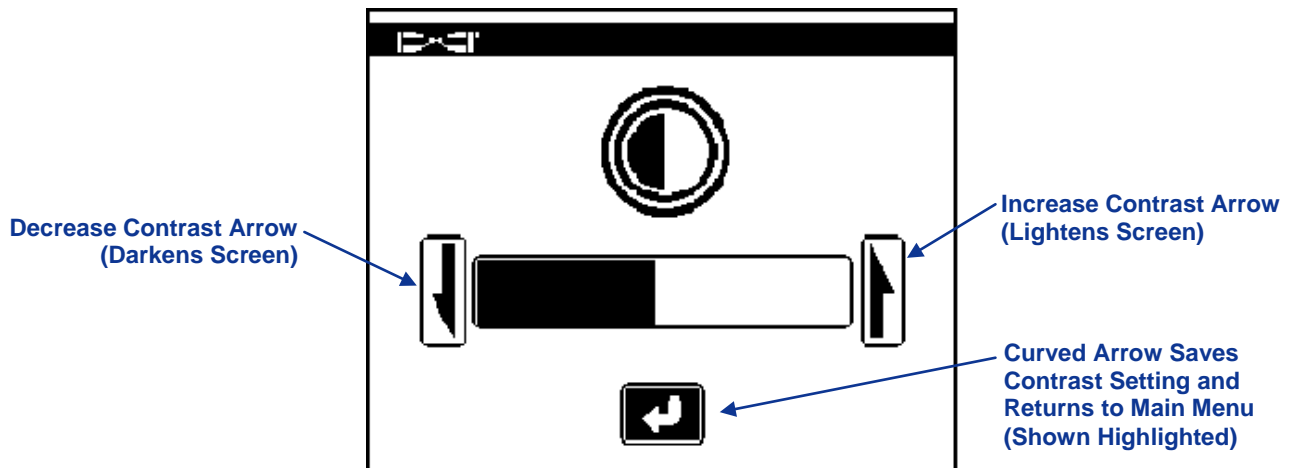

### Adjust Screen Contrast

Using the left or right direction button on the remote, highlight the decrease contrast or increase contrast arrow as shown on the screen above. Then, adjust the contrast by pressing the execute button on the remote. Each time the execute button is pressed, the contrast will change incrementally. When the contrast is adjusted, use the left/right direction buttons on the remote to highlight the curved arrow on the screen, as shown above, and press the execute button to return to the main menu.

## Settings Menu

The settings menu is accessed by selecting the settings menu option at the main menu screen. If you are using a Mark Series locating system, the depth and pitch unit options will not be available; these units can only be changed at the receiver.

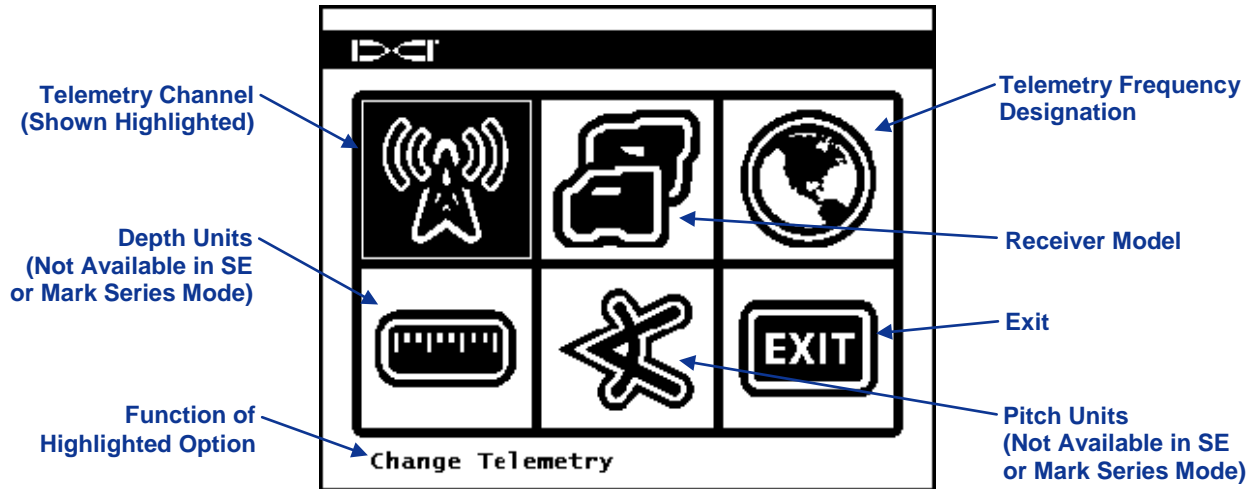

**Settings Menu Screen**

The table below shows the menu options as they appear on the display with descriptions of their uses. Any changes that are made to the settings will be saved when the remote is turned off. DCI recommends that you program the MFD or FSD settings to match the settings on your receiver.

### Settings Menu Options

	<p><b>Telemetry Channel</b> – Opens the telemetry channel options. There are four channel options for the Mark Series, F2, and SE modes: 1, 2, 3, 4. The Eclipse mode has eight channel options: A (1, 2, 3, 4) and B (B1, B2, B3, B4). Telemetry option B is recommended for the Eclipse System. The remote and receiver must have the same telemetry frequency designation and be set to the same telemetry channel.</p>
	<p><b>Receiver Model</b> – Allows you to program the remote to work with an F2, Eclipse, SE, or Mark Series receiver. Software updates may be required for older MFD and FSD remotes to display the SE mode option. Use Mark Series mode with an SE receiver if there is not an SE option.</p>
	<p><b>Telemetry Frequency Designation</b> – Opens the telemetry region options. If you must change this setting, call DCI to determine which setting is required in your area and to verify that it matches the receiver frequency.</p>
	<p><b>Depth Units</b> – Allows you to select distance units as either English or metric. When English units are selected, temperature will display in degrees Fahrenheit (°F). When metric units are selected, temperature will display in degrees Celsius (°C).</p>
	<p><b>Pitch Units</b> – Allows you to select pitch angle units. The options are percent (%) or degree (°).</p>
	<p><b>Exit Menu</b> – Exits the settings menu and returns to the main menu screen. After a setting is changed, the exit option is automatically highlighted for selection.</p>



**Notes**

## Remote Modes

The main display screen for the last remote mode setting is the default screen when you turn on the MFD or FSD remote display. It shows the transmitter pitch, roll, battery status, and temperature. The MFD or FSD battery status, receiver model, telemetry channel, telemetry update meter, and *Target Steering* data (if active) are also displayed on the main screen.

### F2 and Eclipse Modes

#### Main Display Screens

The F2 and Eclipse modes have essentially the same screen display. The only significant difference between the Eclipse and the F2 display modes is that the Eclipse mode will display roll at the ½ clock positions as well as the standard 12 clock positions. The number of clock positions that display is a function of the transmitter.

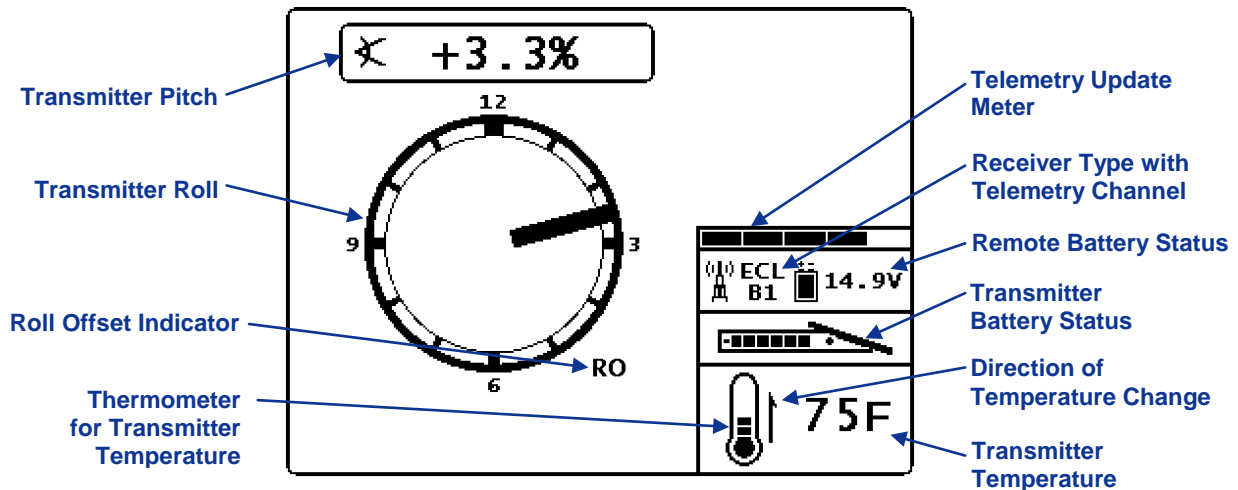

**DigiTrak F2 and Eclipse Main Display Screen**

The telemetry update meter displays the amount of signal being received. If less data is being received, then fewer bars are shown on the meter. If the meter is decreasing or low, you should pause before making steering decisions to ensure you have correct data. When the meter is empty, telemetry data is not being received and the information will disappear.

The roll offset indicator displays when the receiver has been programmed to compensate for a difference between the transmitter's 12 o'clock and the drill head's 12 o'clock positions.

## Depth Display Screens

The depth or predicted depth of the transmitter can be viewed on the remote display, but only when the receiver is positioned at the locate line (LL) or at the front locate point (FLP) with its trigger held in. See the operator's manual provided with your DCI locating system for information on correctly positioning the receiver.

When the receiver is positioned at the LL with its trigger held in, the remote's display will change to show the depth reading with arrows pointing to the ground and the drill head. When the height-above-ground (HAG) function is turned on, the receiver is shown elevated with its HAG setting displayed. In the figure below you can see that the HAG setting is 1'10" to indicate that the receiver is being held that distance above the ground. See the operator's manual provided with your DCI locating system for information on using the HAG function.

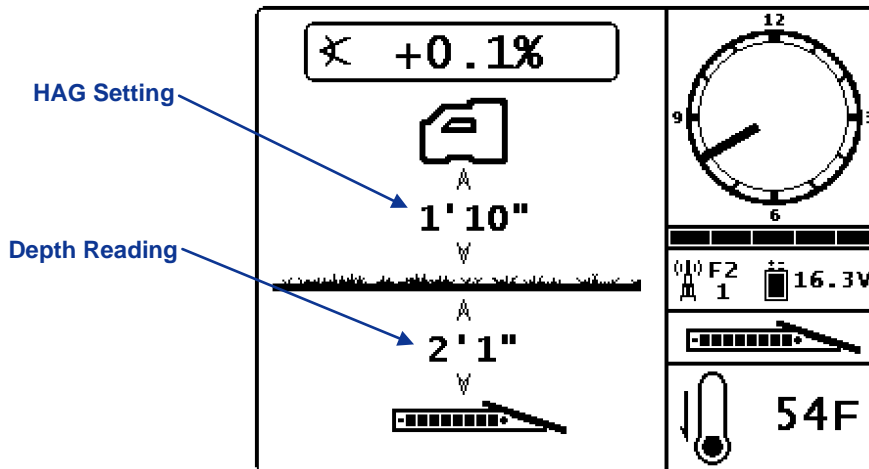

**Depth Display at the Locate Line with HAG On**

The depth data will display for 10 seconds after the trigger on the receiver is released, and then the display will return to the main display screen.

The predicted depth display screen appears when the receiver is positioned at the FLP or the RLP (rear locate point) and the trigger is held in. However, the predicted depth is only valid at the FLP. The predicted depth display will show arrows pointing to the receiver and the predicted depth point ahead of the transmitter.

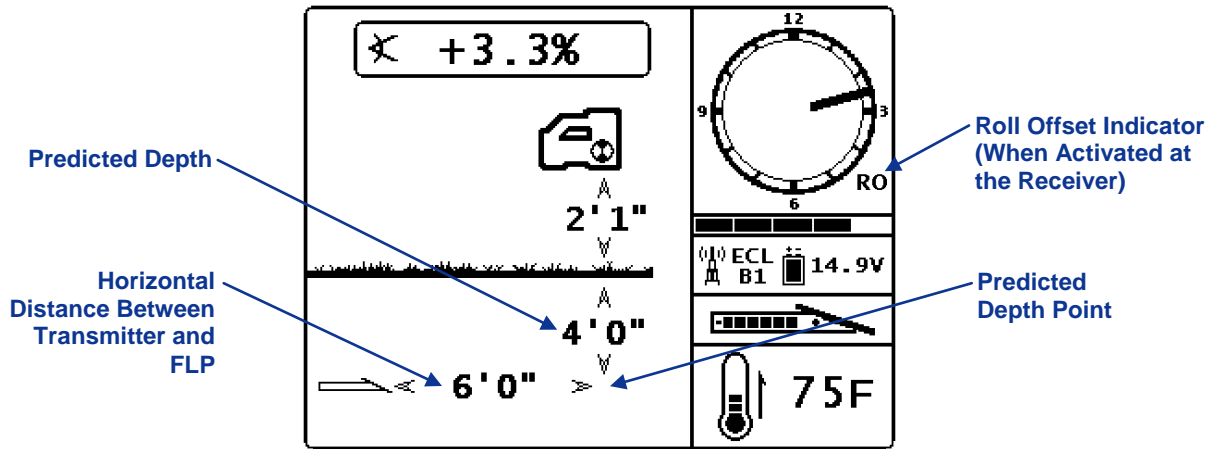

**Predicted Depth Display with HAG On**

When the transmitter pitch information cannot be obtained at the receiver due to range restrictions or interference, the remote will assume the transmitter has a pitch of zero for depth and predicted depth readings. In this case, the following image will appear on the depth or predicted depth mode screen.

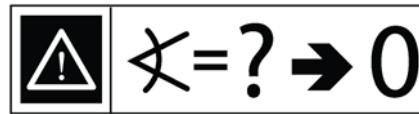

**Pitch Assumed Zero**

## Target Steering Display Screen

The *Target Steering* display screen, shown below, will appear when the receiver has been programmed with a target depth value.

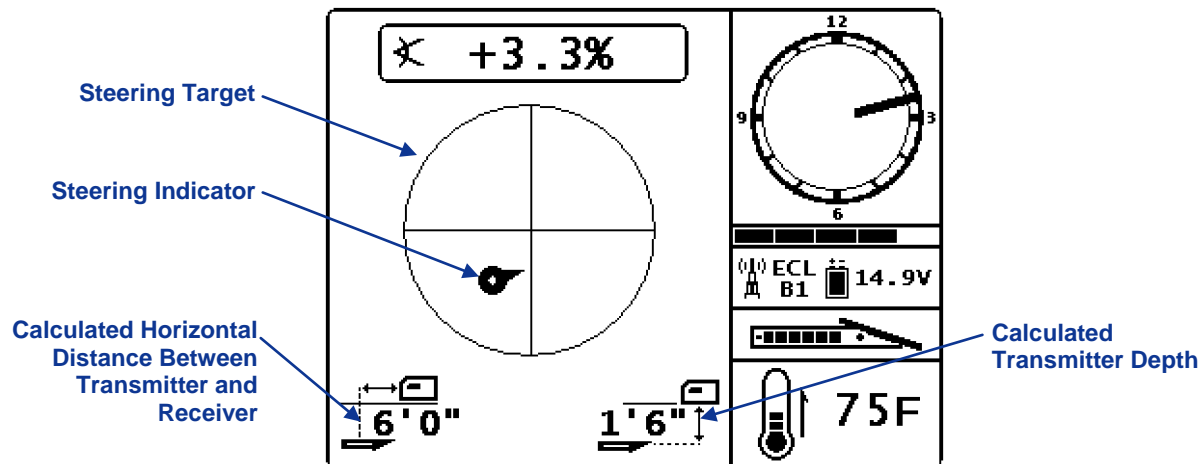

**Target Steering Display**

The calculated horizontal distance and depth shown on the *Target Steering* display are only correct when the receiver is properly positioned beyond the front locate point and within the range limits of the transmitter and remote. See the operator’s manual provided with your DCI locating system for information on how to activate *Target Steering* and correctly position the receiver.

## TensiTrak Mode (Eclipse Only)

When using the Eclipse TensiTrak Pullback and Pressure Monitoring System with the remote programmed to Eclipse mode, you will see the TensiTrak data screen shown below.

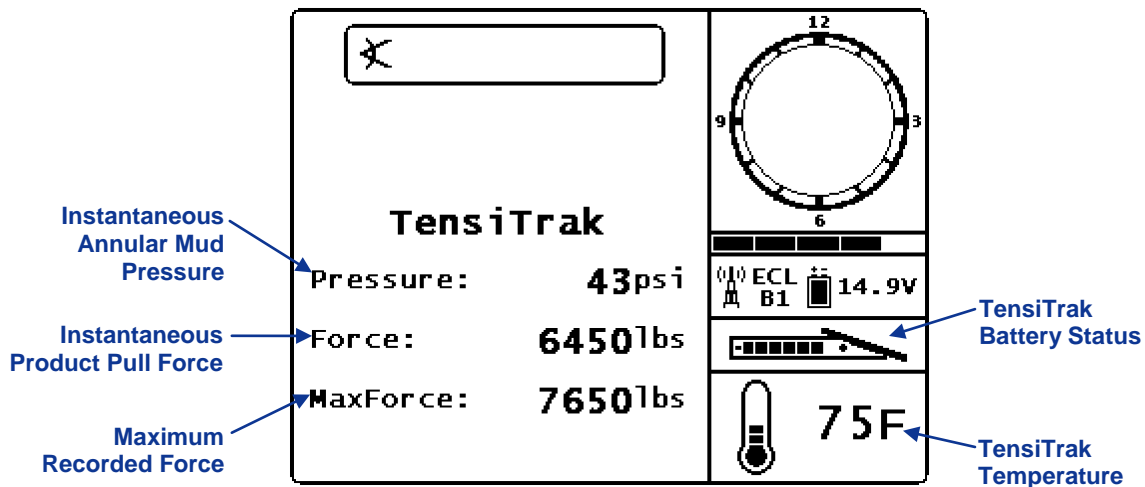

**TensiTrak Data Screen**

As the product’s maximum recorded force (MaxForce) and instantaneous annular mud pressure (Pressure) increase, the remote will emit tones as shown in the following table.

### TensiTrak Force and Pressure Warning Tones

Event	Warning Tones
MaxForce increases by 2000 lb (8.9 kN)	Single beep
Pressure increases by 5 psi (34 kPa) up to 40 psi (276 kPa)	Single beep
Pressure increases by 5 psi (34 kPa) from 40 to 50 psi (276–345 kPa)	Double beep
Pressure increases by 5 psi (34 kPa) from 50 to 60 psi (345–414 kPa)	Triple Beep

For additional information about the TensiTrak Pullback and Pressure Monitoring System, contact DCI.

## SE Series Mode

The SE mode is used with an SE receiver. Software updates may be required for older MFD and FSD remotes to display the SE mode option. If you are using an older remote with an SE receiver and have not yet upgraded the remote to have the SE mode option, then use Mark Series mode; the Mark IV/V screens will display.

### Main Display Screen

After entering the SE mode, confirm that the telemetry channel matches that of the receiver. The same depth and pitch measurement units as set on the receiver will display on the remote.

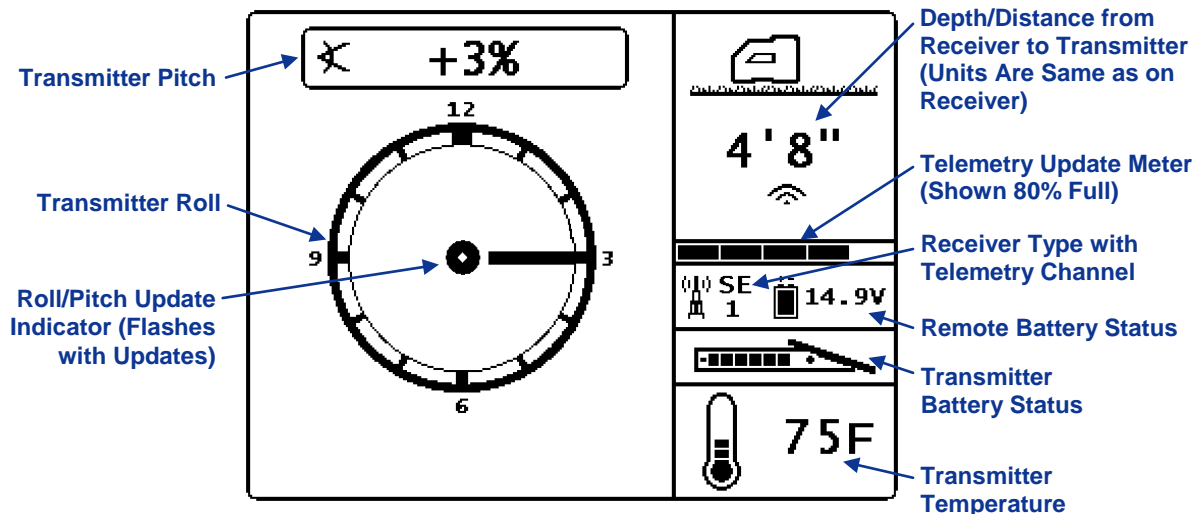

**DigiTrak SE Main Display Screen**

The telemetry update meter displays the amount of signal being received. If less data is being received, then fewer bars are shown on the meter. If the meter is decreasing or low, you should pause before making steering decisions to ensure you have correct data. When the meter is empty, all data will disappear.

A roll offset indicator (RO) will display next to the clock, as shown on the DigiTrak F2 and Eclipse main display screens, when the receiver has been programmed to compensate for a difference between the transmitter's 12 o'clock and the drill head's 12 o'clock positions.

### Depth Display Screens

The depth or predicted depth of the transmitter can be viewed on the remote display when the SE receiver is positioned at the locate line (LL). See the operator's manual provided with you SE locating system for information on correctly positioning the receiver.

When the receiver is positioned at the LL and its trigger is held in, the remote display screen will change to show the depth measurement with arrows pointing to the ground and the drill head. When the height-above-ground (HAG) function is turned on, the receiver icon is shown elevated with its HAG setting displayed. In the figure below you can see that the HAG setting is 1' 2" to indicate that the receiver is being held that distance above the ground. See your SE system operator's manual for information on using the HAG function.

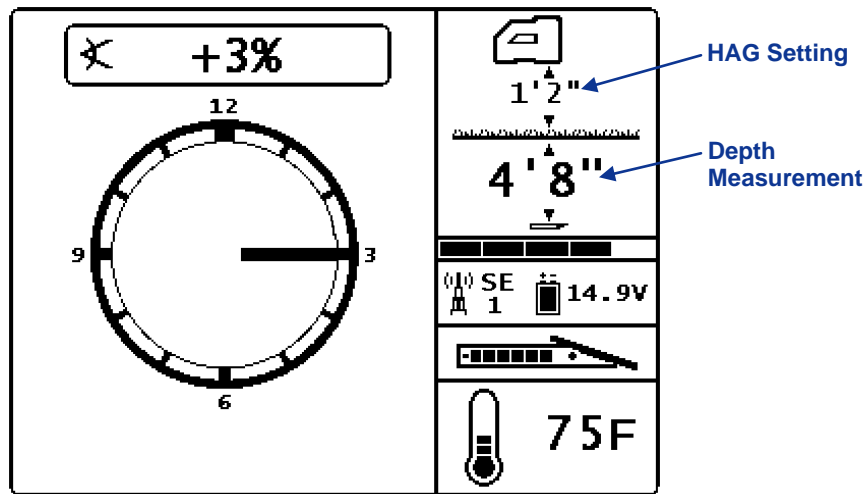

**DigiTrak SE Depth Display Screen with HAG On**

The depth data will display for 10 seconds after the trigger on the receiver is released, and it will then return to the main screen display.

The predicted depth display screen appears when the receiver is positioned at the FLP or the RLP (rear locate point) and the trigger is held in. However, the predicted depth is only valid at the FLP. The predicted depth display will show arrows pointing to the receiver and the predicted depth point ahead of the transmitter.

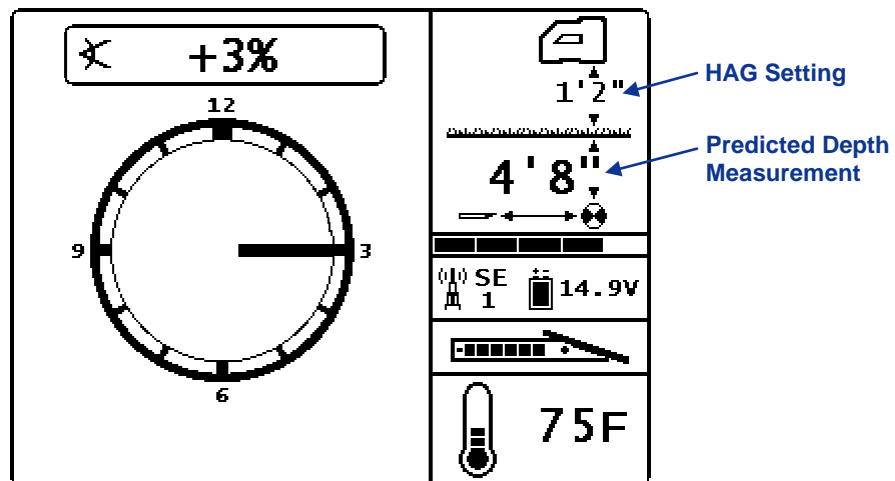

**DigiTrak SE Predicted Depth Display with HAG On**

When the transmitter pitch information cannot be obtained at the receiver due to range restrictions or interference, the remote will assume the transmitter has a pitch of zero for depth and predicted depth readings. In this case, the following image will appear on the depth or predicted depth mode screen.

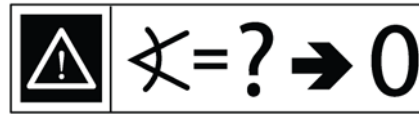

*Pitch Assumed Zero*

## Remote Steering Display Screen

The remote steering display screen, shown below, will appear when remote steering has been turned on at the receiver. See the SE system operator's manual for more information.

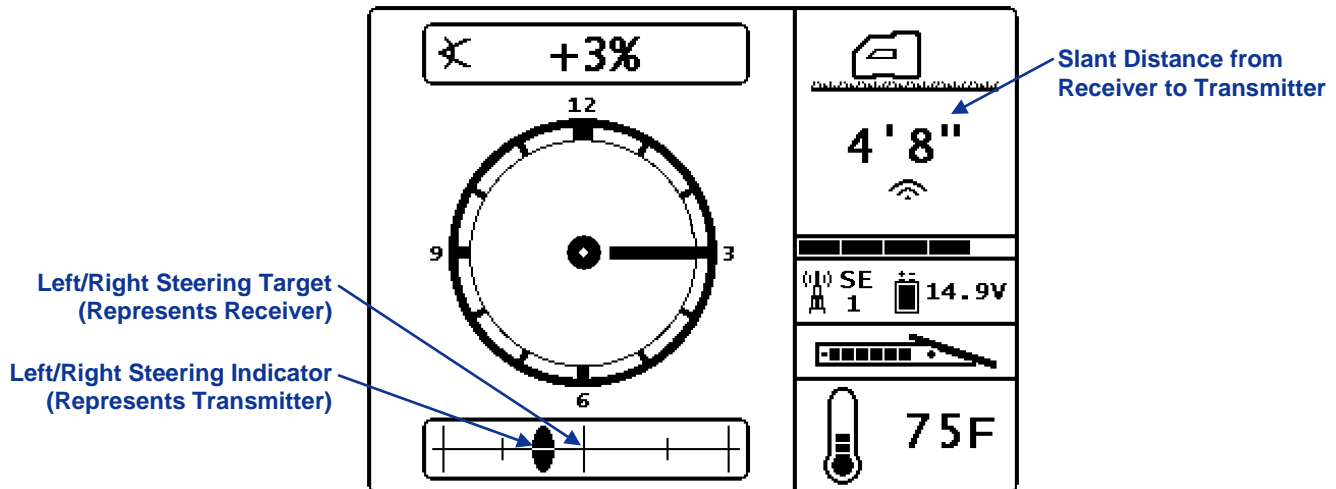

*DigiTrak SE Remote Steering Display*

The remote steering information is only correct when the receiver is properly positioned beyond the front locate point and within the range limits of the transmitter and remote. See your SE system operator's manual for information on how to activate remote steering and correctly position the receiver.

## Mark Series Mode

The Mark Series mode is used with a DigiTrak Mark II, Mark III, Mark IV, or Mark V receiver. The remote will automatically detect which receiver is being used and show the appropriate screen.

After entering the Mark Series mode, you should confirm that the telemetry channel on the remote matches that on the receiver. The same depth and pitch measurement units set on the receiver will display on the remote.

**NOTE:** The SE receiver is used with the MFD/FSD remote in Mark Series mode if the remote does not have updated software with the SE receiver mode option. The Mark IV/V screens will display.

### Main Display Screens (Mark II, III, IV, and V)

When a Mark II or Mark III receiver is used, the data screen shown below will display. The depth/distance shown for either system may not be the actual depth; it could be the slant distance. For the most accurate depth reading, the receiver must be positioned over the drill head or at the front locate point (see the operator's manual provided with your DCI locating system).

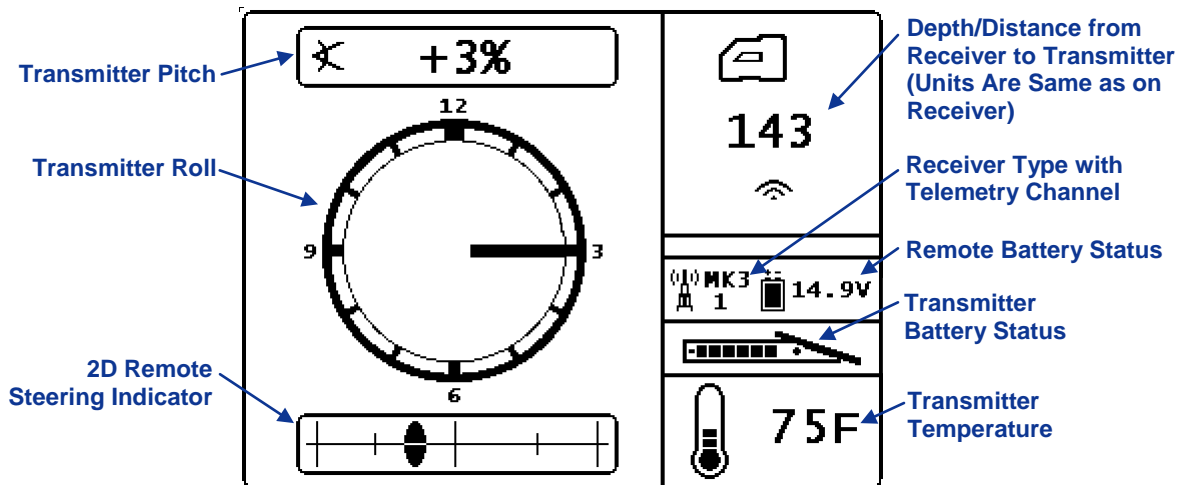

**DigiTrak Mark II/III Main Display Screen**

**NOTE:** If you are using a Mark II receiver, you will still see MK3 as the receiver type.

The telemetry update meter is not active when the remote is in Mark Series mode. Updates from the transmitter are indicated by the flashing dot in the center of the clock, as illustrated in the Mark IV/V main display screen shown below. The dot flashes at about 2-second intervals. When telemetry data is not available, the dot will not appear and no transmitter data will display.

The Mark IV/V main display screen will appear when a Mark IV or Mark V receiver is used. All symbols have the same representation as described for the Mark II/III screen shown above.

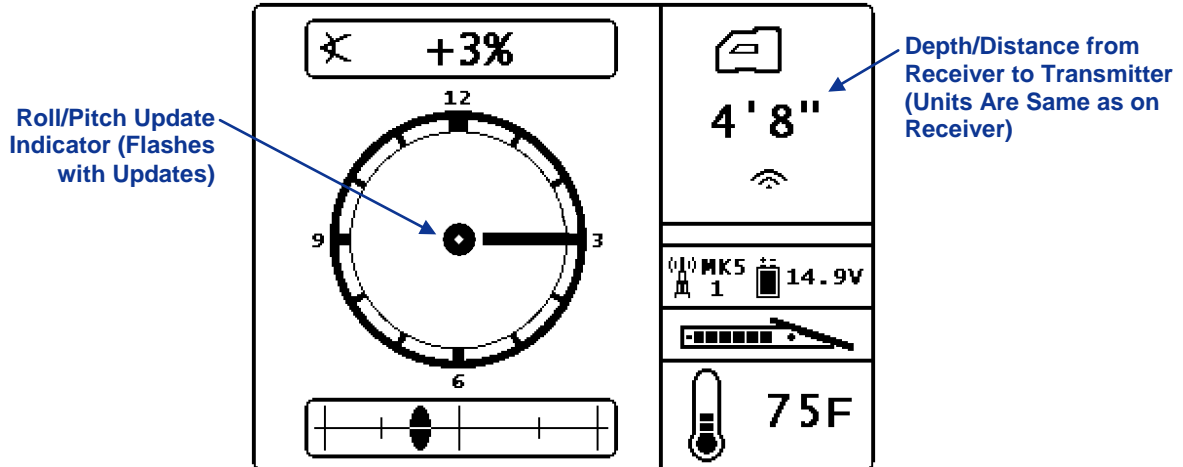

**DigiTrak Mark IV/V Main Display Screen**

The main display screen is the only screen that will display when using a Mark II or Mark III receiver. When using a Mark IV or Mark V receiver, depth and predicted depth screens will display as described below.

## Depth Display Screens (Mark IV/V)

Once the Mark IV or Mark V receiver is positioned at the locate line and the trigger is held in, the depth information will be displayed as shown in the figure below. The vertical arrows pointing to the drill head and the receiver indicate that the reading is a depth measurement and not the slant distance to the head.

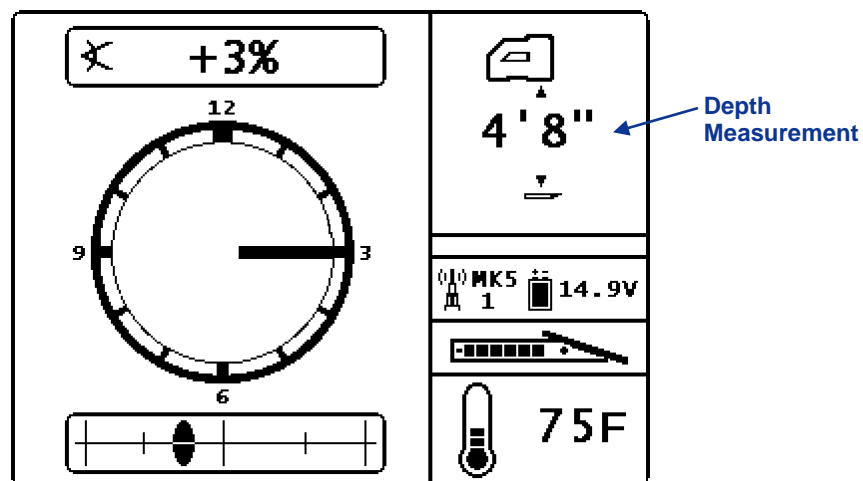

**DigiTrak Mark IV/V Depth Screen**

If the DigiTrak Mark IV or Mark V receiver is positioned at the front locate point (FLP) and the trigger is held in, you will see the predicted depth screen shown below.

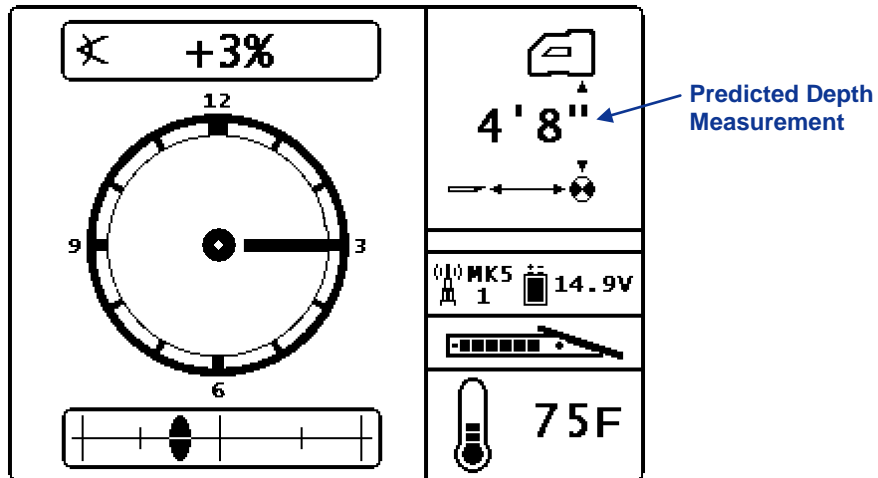

***DigiTrak Mark IV/V Predicted Depth Screen***

Notice that there are vertical arrows pointing to the target and the receiver in front of the drill head. These arrows indicate that the depth measurement displayed is the predicted depth of the drill head when it reaches the point below the receiver at the FLP.

## LIMITED WARRANTY

Digital Control Incorporated ("DCI") warrants that when shipped from DCI each DCI product ("DCI Product") will conform to DCI's current published specifications in existence at the time of shipment and will be free, for the warranty period ("Warranty Period") described below, from defects in materials and workmanship. The limited warranty described herein ("Limited Warranty") is not transferable, shall extend only to the first end-user ("User") purchasing the DCI Product from either DCI or a dealer expressly authorized by DCI to sell DCI Products ("Authorized DCI Dealer"), and is subject to the following terms, conditions and limitations:

1. A Warranty Period of twelve (12) months shall apply to the following new DCI Products: receivers/locators, remote displays, battery chargers and rechargeable batteries, and DataLog<sup>®</sup> modules and interfaces. A Warranty Period of ninety (90) days shall apply to all other new DCI Products, including transmitters, accessories, and software programs and modules. Unless otherwise stated by DCI, a Warranty Period of ninety (90) days shall apply to: (a) a used DCI Product sold either by DCI or by an Authorized DCI Dealer who has been expressly authorized by DCI to sell such used DCI Product; and (b) services provided by DCI, including testing, servicing, and repairing an out-of-warranty DCI Product. The Warranty Period shall begin from the later of: (i) the date of shipment of the DCI Product from DCI, or (ii) the date of shipment (or other delivery) of the DCI Product from an Authorized DCI Dealer to User.

2. DCI's sole obligation under this Limited Warranty shall be limited to either repairing, replacing, or adjusting, at DCI's option, a covered DCI Product that has been determined by DCI, after reasonable inspection, to be defective during the foregoing Warranty Period. All warranty inspections, repairs and adjustments must be performed either by DCI or by a warranty claim service authorized in writing by DCI. All warranty claims must include proof of purchase, including proof of purchase date, identifying the DCI Product by serial number.

**3. The Limited Warranty shall only be effective if: (i) within fourteen (14) days of receipt of the DCI Product, User mails a fully-completed Product Registration Card to DCI; (ii) User makes a reasonable inspection upon first receipt of the DCI Product and immediately notifies DCI of any apparent defect; and (iii) User complies with all of the Warranty Claim Procedures described below.**

## **WHAT IS NOT COVERED**

This Limited Warranty excludes all damage, including damage to any DCI Product, due to: failure to follow DCI's user's manual and other DCI instructions; abuse; misuse; neglect; accident; fire; flood; Acts of God; improper applications; connection to incorrect line voltages and improper power sources; use of incorrect fuses; overheating; contact with high voltages or injurious substances; or other events beyond the control of DCI. This Limited Warranty does not apply to any equipment not manufactured or supplied by DCI nor, if applicable, to any damage or loss resulting from use of any DCI Product outside the designated country of use. By accepting a DCI Product and not returning it for a refund within thirty (30) days of purchase, User agrees to the terms of this Limited Warranty, including without limitation the Limitation of Remedies and Liability described below, and agrees to carefully evaluate the suitability of the DCI Product for User's intended use and to thoroughly read and strictly follow all instructions supplied by DCI (including any updated DCI Product information which may be obtained at the above DCI website). In no event shall this Limited Warranty cover any damage arising during shipment of the DCI Product to or from DCI.

User agrees that the following will render the above Limited Warranty void: (i) alteration, removal or tampering with any serial number, identification, instructional, or sealing labels on the DCI Product, or (ii) any unauthorized disassembly, repair or modification of the DCI Product. In no event shall DCI be responsible for the cost of or any damage resulting from any changes, modifications, or repairs to the DCI Product not expressly authorized in writing by DCI, and DCI shall not be responsible for the loss of or damage to the DCI Product or any other equipment while in the possession of any service agency not authorized by DCI.

DCI reserves the right to make changes in design and improvements upon DCI Products from time to time, and User understands that DCI shall have no obligation to upgrade any previously manufactured DCI Product to include any such changes.

**THE FOREGOING LIMITED WARRANTY IS DCI'S SOLE WARRANTY AND IS MADE IN PLACE OF ALL OTHER WARRANTIES, EXPRESS OR IMPLIED, INCLUDING BUT NOT LIMITED TO THE IMPLIED WARRANTIES OF MERCHANTABILITY AND FITNESS FOR A PARTICULAR PURPOSE AND ANY IMPLIED WARRANTY ARISING FROM COURSE OF PERFORMANCE, COURSE OF DEALING, OR USAGE OF TRADE, ALL OF WHICH ARE HEREBY DISCLAIMED AND EXCLUDED.** If DCI has substantially complied with the warranty claim procedures described below, such procedures shall constitute User's sole and exclusive remedy for breach of the Limited Warranty.

## LIMITATION OF REMEDIES AND LIABILITY

**In no event shall DCI nor anyone else involved in the creation, production, or delivery of the DCI Product be liable for any damages arising out of the use or inability to use the DCI Product, including but not limited to indirect, special, incidental, or consequential damages or for any cover, loss of information, profit, revenue or use based upon any claim by User for breach of warranty, breach of contract, negligence, strict liability, or any other legal theory, even if DCI has been advised of the possibility of such damages. In no event shall DCI's liability exceed the amount User has paid for the DCI Product. To the extent that any applicable law does not allow the exclusion or limitation of incidental, consequential or similar damages, the foregoing limitations regarding such damages shall not apply.**

This Limited Warranty gives you specific legal rights, and you may also have other rights which vary from state to state. This Limited Warranty shall be governed by the laws of the State of Washington.

## WARRANTY CLAIM PROCEDURES

1. If you are having problems with your DCI Product, you must first contact the Authorized DCI Dealer where it was purchased. If you are unable to resolve the problem through your Authorized DCI Dealer, contact DCI's Customer Service Department in Kent, Washington, USA at the above telephone number between 6:00 a.m. and 6:00 p.m. Pacific Time and ask to speak with a customer service representative. (The above "800" number is available for use only in the USA and Canada.) Prior to returning any DCI Product to DCI for service, you must obtain a Return Merchandise Authorization (RMA) number. Failure to obtain a RMA may result in delays or return to you of the DCI Product without repair.
2. After contacting a DCI customer service representative by telephone, the representative will attempt to assist you in troubleshooting while you are using the DCI Product during actual field operations. Please have all related equipment available together with a list of all DCI Product serial numbers. It is important that field troubleshooting be conducted because many problems do not result from a defective DCI Product, but instead are due to either operational errors or adverse conditions occurring in the User's drilling environment.
3. If a DCI Product problem is confirmed as a result of field troubleshooting discussions with a DCI customer service representative, the representative will issue a RMA number authorizing the return of the DCI Product and will provide shipping directions. You will be responsible for all shipping costs, including any insurance. If, after receiving the DCI Product and performing diagnostic testing, DCI determines the problem is covered by the Limited Warranty, required repairs and/or adjustments will be made, and a properly functioning DCI Product will be promptly shipped to you. If the problem is not covered by the Limited Warranty, you will be informed of the reason and be provided an estimate of repair costs. If you authorize DCI to service or repair the DCI Product, the work will be promptly performed and the DCI Product will be shipped to you. You will be billed for any costs for testing, repairs and adjustments not covered by the Limited Warranty and for shipping costs. In most cases, repairs are accomplished within 1 to 2 weeks.
4. DCI has a limited supply of loaner equipment available. If loaner equipment is required by you and is available, DCI will attempt to ship loaner equipment to you by overnight delivery for your use while your equipment is being serviced by DCI. DCI will make reasonable efforts to minimize your downtime on warranty claims, limited by circumstances not within DCI's control. If DCI provides you loaner equipment, your equipment must be received by DCI no later than the second business day after your receipt of loaner equipment. You must return the loaner equipment by overnight delivery for receipt by DCI no later than the second business day after your receipt of the repaired DCI Product. Any failure to meet these deadlines will result in a rental charge for use of the loaner equipment for each extra day the return of the loaner equipment to DCI is delayed.